

SDDS Quick Reference Guide

NO DIGITAL PLAYBACK

- Confirm that the power to the SDDS System is "ON" & the film has SDDS data tracks on both edges of the film. Refer to Figure 6
- Ensure that Film is threaded properly through the SDDS Reader Unit (DFP-R2000), refer to Figure 1

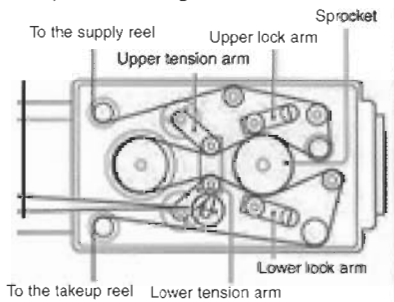

Figure 1

- Ensure that the film tension is set properly in the SDDS Reader Unit (DFP-R2000), refer to Figure 2.

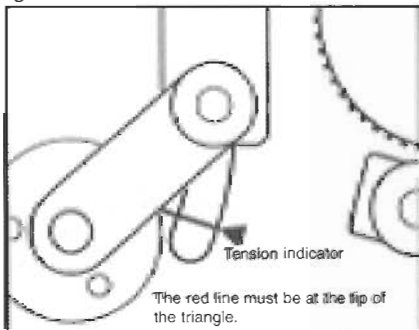

Figure 2

- Ensure that the "DATA PRESENT" & "SYSTEM OK" LEDs on the SDDS Decoder front panel is illuminated steadily, refer to Figure 3.

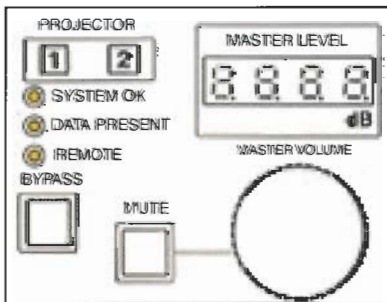

Figure 3

- Ensure that the "BYPASS" & "MUTE" keys are NOT illuminated, refer to Figure 3.

DIGITAL SOUND "CUTS OUT"

- After confirming correct tension (refer to Figure 2), ensure that the SDDS reader lenses are clean. Also verify that the light fibers are clean and illuminating a visible red light.
- Open the front panel of the SDDS Decoder (DFP-D2000), refer to Figure 4, and verify that the "S" & "P" data OK LEDs inside the processor are illuminated steadily, refer to Figure 5.

Loosen the Panel Switching Screw and open the Front Panel.

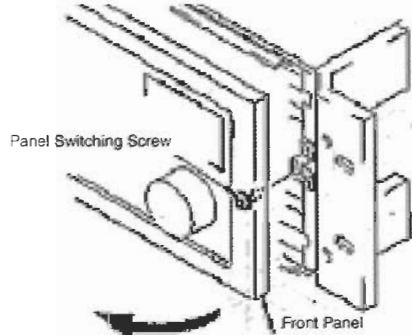

Figure 4

DFP-D2000 Inside Front Panel

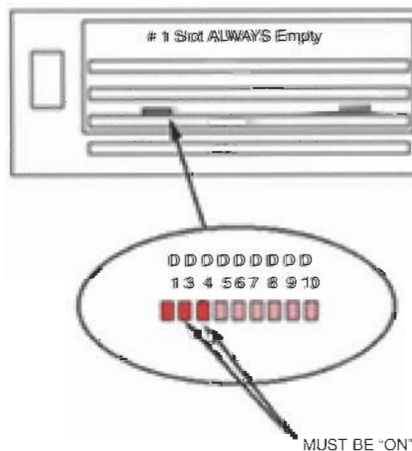

Figure 5

- Attempt to play the print on another SDDS system to confirm the print quality. If the playback fails on another SDDS unit, it is likely that the print is damaged or faulty.

GENERAL MAINTENANCE & PRECAUTIONS

- DO NOT "SLAM" Film Retainer Rollers onto Sprocket Wheel. This can damage the roller and cause the roller to come into contact with the film edges, thus causing edge damage.
- Maintain a clean film path. Clean all rollers, lenses, and light fibers everyday with a clean dry photographic lens cleaning paper or cloth. For details, refer to pages 2-1 through 2-3 of the DFP-R2000 Maintenance Manual (available through your SDDS dealer)
- DO NOT USE ANY SPRAY LUBRICANT OR CLEANER SOLVENT ON THE SDDS EQUIPMENT!
- Do not mark splice points on a plattered print with excessively long permanent ink, polish, etc. ONLY mark the splice for the length of the splicing tape (approximately 1 inch). Adherence to this procedure will ensure proper digital playback through the splice points of the film.

Figure 6

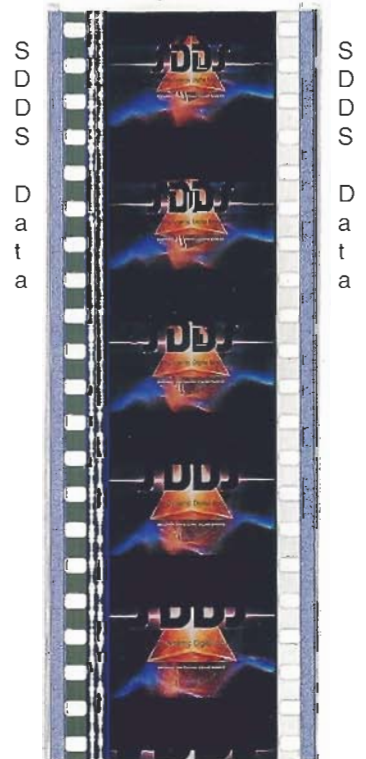

Sony Cinema Products Corporation
Engineering Services Division
Tel: (310) 559-4811
Fax: (310) 559-4097